

Chopper/Wet-out Systems

Low-Emission Resin Systems for the Composites Industry



GlasCraft® Chopper/Wet-out Systems

Outstanding performance for resin applications

Designed to accurately meter and chop fiberglass into a resin spray to provide structural strength to the end product, GlasCraft Chopper/Wet-out Dispense Systems are engineered to deliver reliable performance. Built with fewer wear items, GlasCraft equipment consumes fewer replacement parts. With reduced service expenses and less revenue lost due to downtime, GlasCraft's Chopper Systems are highly economical to own and operate.

GlasCraft Chopper/Wet-out Systems:

- Dispense polyester resin and vinyl ester chemicals
- Allow for infinite adjustment of the catalyst ratio – no tools required
- Offer reliable, highly accurate ratio control
- Provide high-efficiency performance at low spraying pressures
- Available in internal and external mix configurations

Typical applications:

- Marine and watercraft
- Pool and spa
- Bathware
- Transportation
- Corrosion prevention

Dual Upper Seals on Catalyst Pump

- Dual seal prevents leakage – any weepage past the primary seal is returned to the catalyst reservoir, not on the floor

Secondary shaft seal

Primary shaft seal

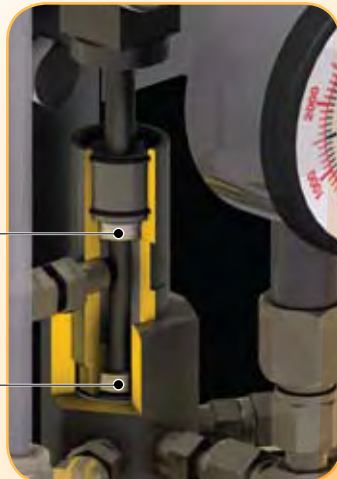

Long-life Design

- Triple-lip spring-loaded seals and hardened cylinders, seats and valves provide long wear life

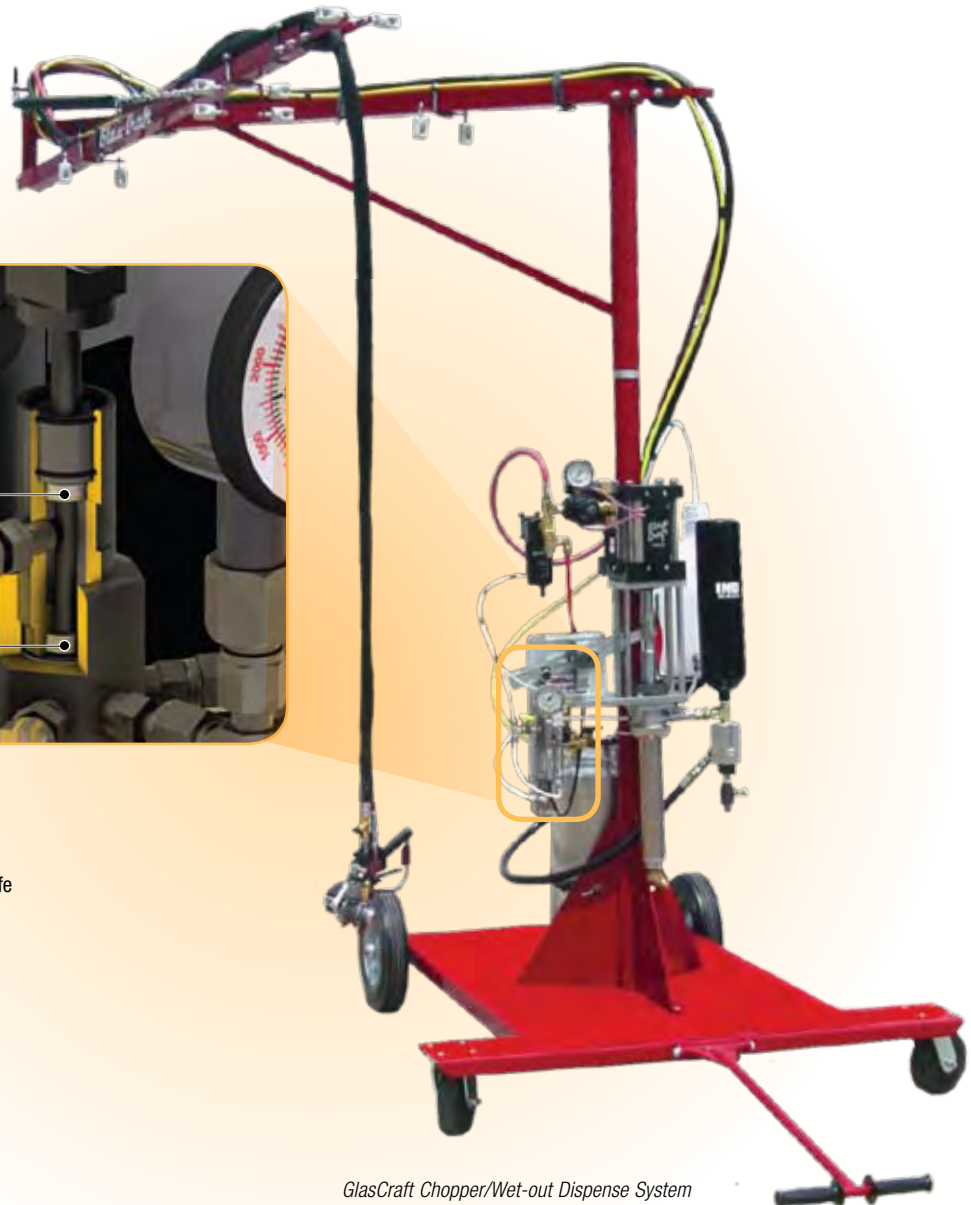

GlasCraft Chopper/Wet-out Dispense System

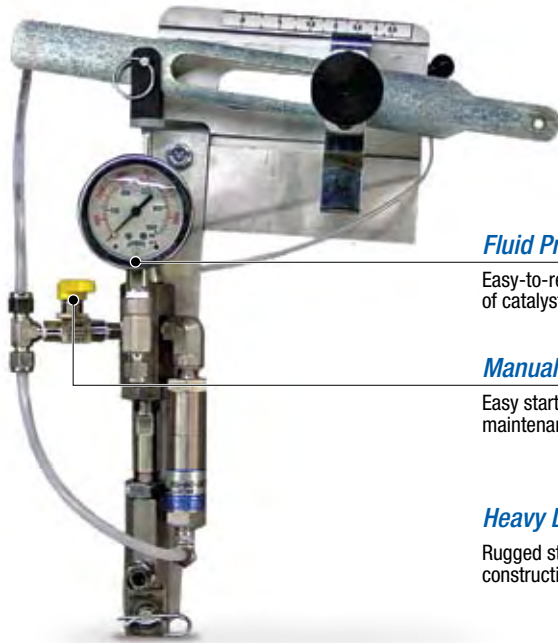

Fluid Pressure Gauge

Easy-to-read gauge for verification of catalyst fluid flow

Manual Relief Valve

Easy startup, shut down and maintenance

Heavy Duty

Rugged stainless steel construction



Precision Air Pilot Valve

Allows fast pneumatic changeover without any parts to wear out

Surge Bottle Accumulator

Ensures consistent pressure for ideal spray pattern

Quick Change Seal Design

- Tool-less quick disconnect allows for easy top seal maintenance
- Lower end is easily removed to service lower seals on pump

Four-inch Stroke

Uses fewer cycles, which means less wear and increased uptime

Adjustable-Ratio Catalyst Pump

- Easy, no-tool quick-change catalyst adjustment
- Ensures proper catalyst percentage and optimal results
- Operates at any desired catalyst percentage within operating range
 - 0.5% to 3.5% for 5:1 system
 - 0.5% to 3.5% for 11:1 system
 - 0.5% to 2.9% for 17:1 system
 - 0.8% to 5.6% for 20:1 system

Resin Pump

- Reliable, low-maintenance reciprocating piston pump for moving polyester resin
- Piston pump works well with fillers
- Standard pump offers 11:1 ratio
- Develops up to 1300 psi (89 bar, 8.9 MPa)
- Delivers up to 2.5 gpm (9.5 lpm)

Optional resin pumps:

5:1 Pump

- For low-pressure applications
- Develops up to 500 psi (34 bar, 3.4 MPa)
- Delivers up to 2.5 gpm (9.5 lpm)

HVRP 17:1 Pump

- Designed for high volume resin or chopper applications
- Ideal for high volume production shops
- Develops up to 1700 psi (117 bar, 11.7 MPa)
- Delivers up to 4.1 gpm (15.5 lpm)

Low VOC 20:1

- For high-viscosity materials
- Develops up to 2000 psi (138 bar, 13.8 MPa)
- Delivers up to 1.6 gpm (6.0 lpm)

Air Assist Containment

Advanced technology to control and contain your spray pattern

When you buy a drum of resin, you pay for every drop of material. It makes good economic sense to put as many of those drops as possible on the mold.

GlasCraft's exclusive Air Assist Containment (AAC) wraps the spray pattern in a containment shield of air – preventing atomized droplets from escaping the spray pattern. Droplets that escape and end up on the floor, wall or employee's clothing are a waste of money.

AAC creates a spray pattern where the droplets travel to the mold at very low pressure. The low speed or "particle velocity" creates very little turbulence or disturbance in the liquid when the droplet makes contact with the mold. Competitive spray guns with higher "particle velocity" create a great deal of turbulence when the droplets impact the mold. Turbulence creates air entrapment which results in porosity. AAC spraying dramatically reduces the chances of air entrapment and porosity.

AAC improves your profit picture

- All GlasCraft external mix spray guns feature the patented AAC technology
- The AAC screw-on option is available for all internal material guns
- Reduces material waste – which results in more molds per drum of material
- Precise catalyst delivery and reduced particle velocity assure the highest quality finish
- Less overspray means a healthier work area for employees

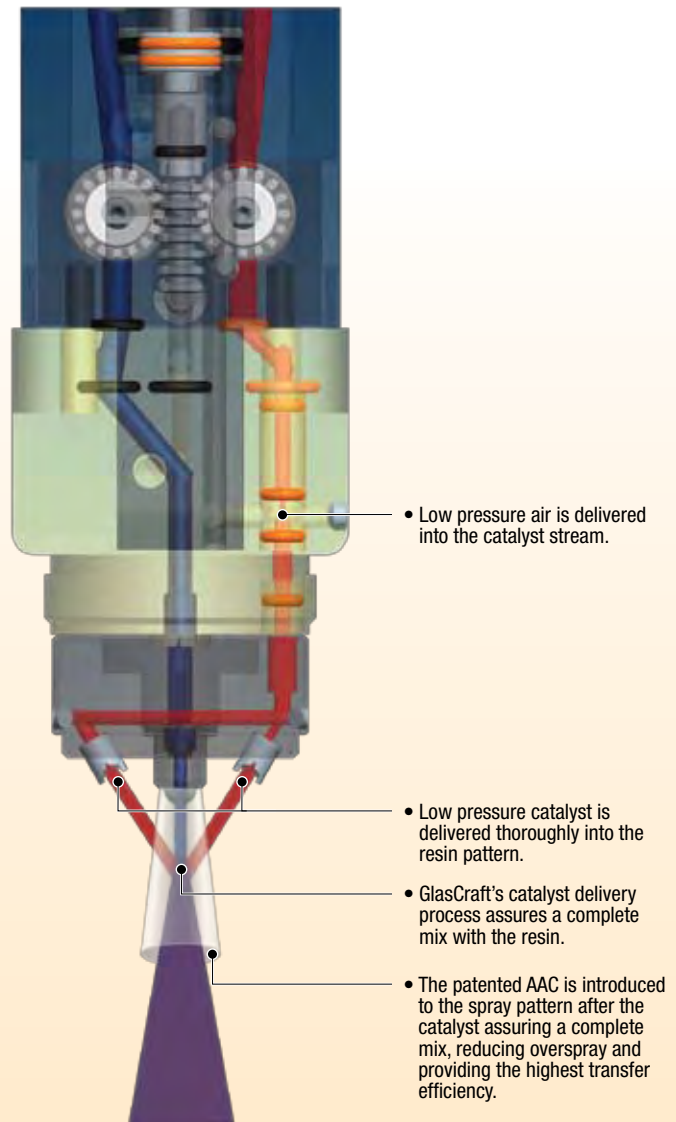
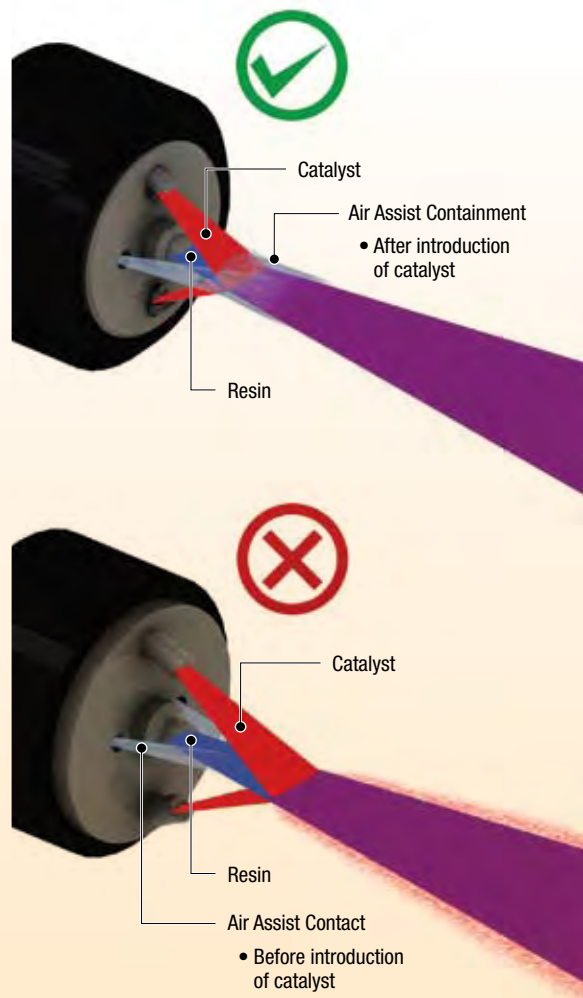

GlasCraft Chopper Spray Guns

Uniform spray pattern

GlasCraft's chopper external guns feature the patented AAC feature to produce the most uniform and consistent low-emission spray pattern with stabilizing air streams.

GlasCraft Formula Guns

- Air-actuated trigger provides immediate response, virtually eliminating hot and cold spots
- No-needle design eliminates needle adjustments
- Special hardened valves are engineered for today's low VOC formulations
- Fluid control occurs via air-operated piston that opens and closes internal ball valves
- Easy access to valve packings for quick maintenance and increased uptime
- Feature AAC technology for uniform spray pattern with minimal overspray



Formula Internal Mix Gun with Chopper

- Precision check valves automatically balance fluid pressures
- Extended mix area results in the best mix



Formula X External Mix Gun with Chopper

- Unique catalyst delivery assures complete integration to the spray pattern
- Easy visual verification of catalyst flow
- No solvent needed to flush

GlasCraft INDy Spray Guns

- Volume control assures the highest quality finish with minimal porosity
- Simple material valve and seat design is easy to maintain, resulting in increased uptime
- Features AAC for excellent pattern control and less wasted material
- Ergonomic, lightweight design reduces operator fatigue



INDy Internal Mix Gun with Chopper

- Fully adjustable pattern control and precision check valves to automatically balance fluid pressures
- Extended mix area results in the best mix



INDy X External Mix Gun with Chopper

- Unique catalyst delivery assures complete integration to the spray pattern
- No solvent needed to flush

What's the difference between external and internal mix guns?

External mix guns:

- Ideal for low-emission resin applications
- Chemical is mixed outside the gun
- Operators can see the catalyst being added to the mix
- Does not require a solvent flush

Internal mix guns:

- Ideal for chopper and wet-out systems
- Ensures the best possible mix
- Because you do not need to pre-atomize the catalyst, there is less forward velocity, which results in less overspray
- Requires a solvent flush for maintenance

Solutions for the Composites Industry

GlasCraft Fiberglass Cutters

Exceptionally quiet, GlasCraft's unique cutter maintains 100 percent torque to the air motor for unchallenged high and low fiber output, and provides the flexibility to pull the fiber from long distances.

All GlasCraft choppers feature superior airflow, which results in a low operating temperature and the best performance with soft glass.

B-410 Cutter

- Unique air flow design results in cooler operating temperature
- Several snout options to efficiently dispense glass in both large and small parts
- Adjustable throttle for output control
- Efficiently pulls one or two strands of glass



B-510 Cutter

- Wide surface area idler bearing allows for even glass disbursement and minimizes glass hang up
- Blower adjustment helps control operating temperature and flow of the glass
- New design cutter wheel for quick and safe blade change
- Automatically keeps proper tension between the blade and wheel for longer tire life and cooler operating temperature
- Fully adjustable snout to easily set the most efficient angle into the resin pattern
- Adjustable throttle for output control
- Efficiently pulls up to three strands of glass

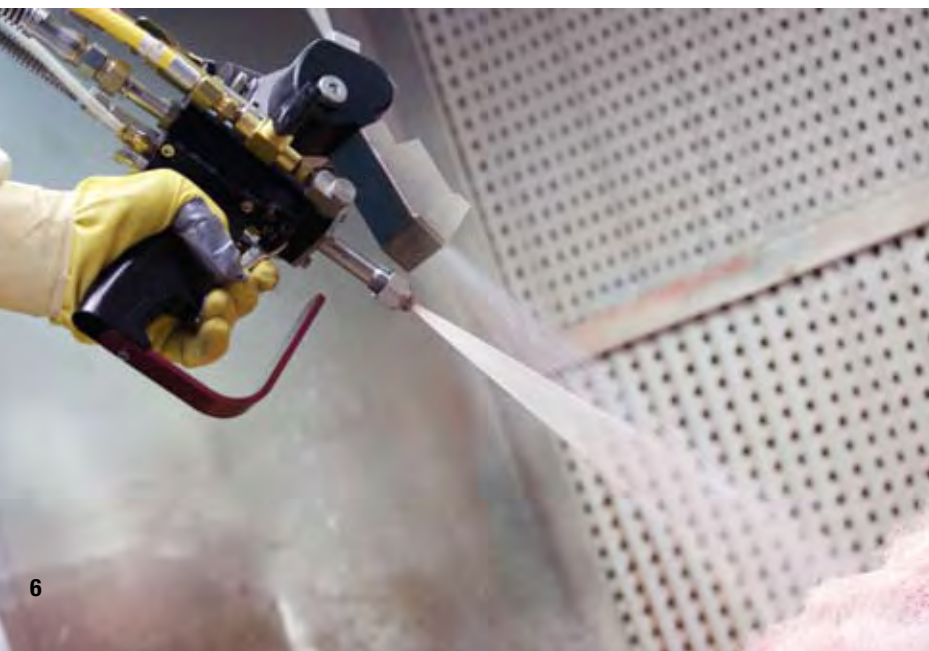

Technical Specifications

	INDy/Formula 5:1	INDy/Formula 11:1	INDy Formula HVRP 17:1	INDy/Formula 20:1
Air requirement	15 cfm @ 100 psi @ max pump output (425 lpm @ 6.8 bar @ max pump output)	35 cfm @ 100 psi max output (991 lpm @ 6.8 bar @ max pump output)	80 cfm @ max output (2265 lpm @ 6.8 bar @ max pump output)	35 cfm @ 100 psi max output (991 lpm @ 6.8 bar @ max pump output)
Material pump capacity*	2.5 gpm (9.5 lpm)	2.5 gpm (9.5 lpm)	4.1 gpm (15.5 lpm)	1.6 gpm (6.0 lpm)
Material pump output	.050 gal per cycle; 20 cycles = 1 gal; 5 cycles = 1 liter	.050 gal per cycle; 20 cycles = 1 gal; 5 cycles = 1 liter	.082 gal per cycle; 12 cycles = 1 gal; 3 cycles = 1 liter	.032 gal per cycle; 31 cycles = 1 gal; 8 cycles = 1 liter
Catalyst slave pump range	0.5% to 3.5%	0.5% to 3.5%	0.5% to 2.9%	0.8% to 5.6%

* Material pump capacity is based on 50 cycles per minute. Higher cycle rates can be achieved depending on material viscosity, material temperature and volume of air. All pump outputs are measured at the pump outlet using a low viscosity test media.

Accessories – Spray Tips

Impingement Style						Airless Style					
Part Number	Orifice	Part Number	Orifice	Part Number	Orifice	Part Number	Orifice	Part Number	Orifice	Part Number	Orifice
23005-C4	0.040	23005-G9	0.090	23005-P4	0.040	LPA2-147-1525	0.015	LPA2-147-2640	0.026	LPA2-147-4350	0.043
23005-C5	0.050	23005-J4	0.040	23005-TC6	0.060	LPA2-147-1540	0.015	LPA2-147-2650	0.026	LPA2-147-4365	0.043
23005-C6	0.060	23005-J5	0.050	23005-TC7	0.070	LPA2-147-1825	0.018	LPA2-147-2665	0.026	LPA2-147-5225	0.052
23005-C7	0.070	23005-J6	0.060	23005-TC8	0.080	LPA2-147-1840	0.018	LPA2-147-3125	0.031	LPA2-147-5240	0.052
23005-C8	0.080	23005-J7	0.070	23005-TE7	0.070	LPA2-147-1850	0.018	LPA2-147-3140	0.031	LPA2-147-5250	0.052
23005-C9	0.090	23005-J8	0.080	23005-TG7	0.070	LPA2-147-2125	0.021	LPA2-147-3150	0.031	LPA2-147-5265	0.052
23005-E4	0.040	23005-J9	0.090	23047-J1	0.012	LPA2-147-2140	0.021	LPA2-147-3625	0.036	LPA2-147-6225	0.062
23005-E5	0.050	23005-K3	0.040	23047-J2	0.014	LPA2-147-2150	0.021	LPA2-147-3640	0.036	LPA2-147-6240	0.062
23005-E6	0.060	23005-K4	0.040	23047-J3	0.022	LPA2-147-2165	0.021	LPA2-147-3650	0.036	LPA2-147-6250	0.062
23005-E7	0.070	23005-K5	0.050	23047-M1	0.012	LPA2-147-2325	0.023	LPA2-147-3840	0.038	LPA2-147-6265	0.062
23005-E8	0.080	23005-K6	0.060	23047-M2	0.014	LPA2-147-2340	0.023	LPA2-147-3850	0.038	LPA2-147-7240	0.072
23005-E9	0.090	23005-K7	0.070	23047-M3	0.022	LPA2-147-2350	0.023	LPA2-147-4325	0.043	LPA2-147-7250	0.072
23005-G4	0.040	23005-K8	0.080	23047-P1	0.012	LPA2-147-2365	0.023	LPA2-147-4340	0.043	LPA2-147-7840	0.078
23005-G5	0.050	23005-K9	0.090	23047-P2	0.014						
23005-G6	0.060	23005-M4	0.040	23047-P3	0.022						
23005-G7	0.070	23005-M5	0.050								
23005-G8	0.080	23005-M6	0.060								

PFRR Option - Add on option for Internal Mix INDY and Formula Guns

GCC238 Pressure Fed Roller Kit, 1.5 ft (0.45m)
GCC239 Pressure Fed Roller Kit, 3 ft (0.91m)
GCC240 Pressure Fed Roller Kit, 6 ft (1.83m)

Not included in the kits above, but required, is a roller cover. Choose a roller cover from below.

20335-01 Roller Cover, 9 in X 1/2 in Nap
20335-02 Roller Cover, 9 in X 3/4 in Nap

Formula/INDY Screw on AAC Gun Head Kit

23570-00 Internal Mix Gel - Screw On AAC Gun Head Kit

NOTE: P/N 23570 requires a regulator assembly which is not included in kit. The following must be ordered for a complete regulator assembly.

Regulator Assembly

3165 Ball Valve
4342-04 Elbow Fitting
7884-07 Elbow Fitting
8115-03 Nipple Fitting
9704-53 Black Aac Tubing
Order length should be fluid hose length plus 3 feet
18199-02 Regulator
18318-02 Gauge
20182-00 AAC Decal

Small Diameter Airless/NON Atomized Material Tip Conversion Parts

20333-00 Gasket
22274-00 Tip Spacer
23002-00 Retaining Nut
LPA2-147-XXXX Spray Tip
23047-Xx Spray Tip
23760-00 Gun Front Housing For Formula Gun Only
23502-00 Gun Front Housing For INDY Gun Only

Formula High/High Filled Resin Mixer conversion Parts

20310-90 3/8 in Mixing Element
23760-01 3/8 in Front Mixer Housing

INDY/Formula RTM Adapter

21652-00 Injection Nozzle
21662-00 Injection Wand
23003-00 Spray Tip Spacer
23049-00 RTM Adapter FTG

INDY/Formula Casting Adapter

20624-00 Jacket Nozzle
20625-00 Mix Nozzle
23003-00 Spray Tip Spacer
23049-00 RTM Adapter FTG

Repair Kits

Formula Gun
23792-00 Gun Air Kit
23793-00 Gun Seal Kit
23732-00 Gun Fluid Valve Kit
INDY Gun
23530-00 Complete Rebuild Kit
23538-00 Maintenance Kit

Catalyst Pump

LPA-190-RK Complete Rebuild Kit
LPA-190-SK Seal Kit

13:1 Air Motor (3.25 in)

20840-00 Complete Service Kit
20104-00 Stroke Signal Repair Kit
20841-00 Cylinder Repair Kit
20842-00 Reciprocating Valve Kit
20843-00 Valve Air Kit

11:1 and 20:1 Air Motor (5 in)

20101-00 Complete Service Kit
20107-00 Pilot Valve Kit
20106-00 Main Valve Kit
20105-00 Gasket Kit
20104-00 Stroke Signal Repair Kit
20103-00 Rod Seal Kit
20102-00 Piston Rod Seal Kit

17:1 Air Motor (6 in)

21380-01 Complete Service Kit
20104-00 Stroke Signal Repair Kit
21381-00 Bushing Rod
21382-01 Air Unit
22343-00 Valve Repair Kit
22344-00 Pilot Valve Kit

Fluid Section

21570-00 5:1/11:1 Repair Kit
19019-01 13:1 Repair Kit
21799-00 17:1 Repair Kit
21277-00 20:1 Repair Kit



ABOUT GRACO

PROVEN QUALITY. LEADING TECHNOLOGY.

Founded in 1926, Graco is a world leader in fluid handling systems and components. Graco products move, measure, control, dispense and apply a wide range of fluids and viscous materials used in vehicle lubrication, commercial and industrial settings.

The company's success is based on its unwavering commitment to technical excellence, world-class manufacturing and unparalleled customer service. Working closely with qualified distributors, Graco offers systems, products and technology that set the quality standard in a wide range of fluid handling solutions. Graco provides equipment for spray finishing, protective coating, paint circulation, lubrication, and dispensing sealants and adhesives, along with power application equipment for the contractor industry. Graco's ongoing investment in fluid management and control will continue to provide innovative solutions to a diverse global market.

GRACO LOCATIONS

MAILING ADDRESS

P.O. Box 1441
Minneapolis, MN 55440-1441
Tel: 612-623-6000
Fax: 612-623-6777

AMERICAS

MINNESOTA

Worldwide Headquarters
Graco Inc.
88-11th Avenue N.E.
Minneapolis, MN 55413

EUROPE

BELGIUM

European Headquarters
Graco N.V.
Industrieterrein-Oude Bunders
Slakweidestraat 31
3630 Maasmechelen,
Belgium
Tel: 32 89 770 700
Fax: 32 89 770 777

ASIA PACIFIC

AUSTRALIA

Graco Australia Pty. Ltd
Suite 17, 2 Enterprise Drive
Bundoora, 3083
Victoria, Australia
Tel: 61 3 946 78558
Fax: 61 3 946 78559

CHINA

Graco Hong Kong Ltd.
Shanghai Representative Office
Room 118 1st Floor
No.2 Xin Yuan Building
No.509 Cao Bao Road
Shanghai, P.R. China 200233
Tel: 86 21 649 50088
Fax: 86 21 649 50077

INDIA

Graco Hong Kong Ltd.
India Liaison Office
Room 103, Level 4, Augusta Point
Golf Course Road
Gurgaon, Haryana, India 122001
Tel: +91 124 435 4208
Fax: +91 124 435 4001

JAPAN

Graco K.K.
1-27-12 Hayabuchi
Tsuzuki-ku
Yokohama City, Japan 2240025
Tel: 81 45 593 7300
Fax: 81 45 593 7301

KOREA

Graco Korea Inc.
Choheung Bank Building
4th Floor #1599
Gwanyang-Dong, Dongan-Ku,
Anyang-Si, Gyeonggi-Do,
Korea 431-060
Tel: 82 31 476 9400
Fax: 82 31 476 9801

SALES/ DISTRIBUTION/ SERVICE

Call today for product information or to request a demonstration.

800-746-1334 or visit us at www.graco.com.

Graco Inc. is registered to I.S. EN ISO 9001

Graco Ohio
800-746-1334
Fax 330-966-3006